

Compact safe with
certified Grade I
burglary protection



Cobra Pro

BURGLARY-RESISTANT PROTECTION

Key Features

- Grade I burglary protection certified by ECB•S in accordance with the European standard, EN 1143-1.
- A Class A mechanical key lock or a Class B high-security electronic lock, approved in accordance with EN 1300, are both available as primary lock options. Electronic locks increase the level of security and prevent unauthorised access to the safe.
- Safes equipped with an electronic lock also have an LED light inside.
- Ergonomic handle, soft-touch handle.
- Interior ladder racking system for flexible positioning of multiple shelves. One shelf is supplied as standard.
- Thinner walls for increased internal capacity.



Chubbsafes
Trusted the world over.

BURGLARY
PROTECTION

Product Specifications

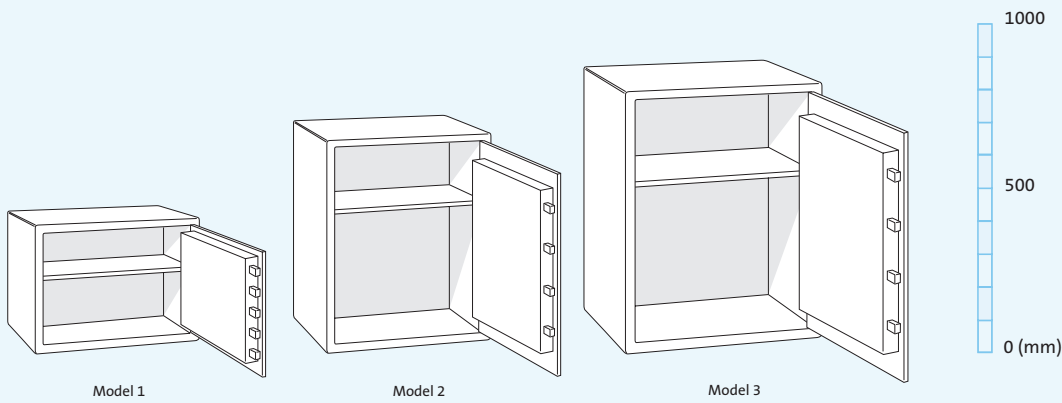

Model	External (mm)			Internal (mm)			Weight (kg)	Volume (litres)
	Height	Width	Depth	Height	Width	Depth		
1	390	500	440	310	420	300	132	40
2	650	500	510	570	420	370	204	88
3	800	600	550	720	520	410	280	153

Lock Options



As the primary locking option, Cobra Pro safes can be fitted with either a high-security electronic lock (Class B) or a key lock (Class A).

Dual locking is available on all models. The primary lock can be complemented by a combination lock or both a key lock and electronic lock can be fitted.



All locks are tested by ECB•S and are certified in accordance with the EN 1300 standard. Cobra Pro's high-security electronic lock – certified Class B by ECB•S – includes the following features:

- 1 master code and 9 user codes.
- Time delay of up to 99 minutes between lock being operated and door being opened. Also equipped with time-delay override.

Burglary Testing

Cobra Pro has been approved by ECB•S in accordance with the European standard, EN 1143-1, for burglary protection in Grades I.

A range of attack tools were used to test Cobra Pro's level of resistance, from basic tools to sophisticated thermal and electrical equipment.



Interior fittings

Shelf

One removable shelf standard with all models. More can be added.

Lighting

Electronic locking models have an integrated LED light inside which turns on when the safe door opens.



Authorised dealer

Chubbsafes
Trusted the world over.

www.chubbsafes.com

'Chubb' is owned by Chubb plc and is a registered trademark used under license